

FREIGHTER



Drop Deck T-Liner

The Freighter Advantages

For more than 50 years, Freighter has been Australia's leading brand of road transport equipment, providing operators with leading edge logistics solutions that deliver maximum payload and maximum versatility.

Freighter's drop deck T-Liner curtainsider semi-trailer, available either in single trailer, lead and tag B-Double or road train configurations, features enhanced stability and safety through its wide spaced beams and wide track axles, with low profile frames that deliver a lower centre of gravity.

The Freighter drop deck T-Liner is available as a 22 pallet or 24 pallet trailer, with a host of available options allowing maximum operational flexibility, including a double drop deck to maximise volume.

The integrity of Freighter engineering allows for minimum tare weight and maximum payload with advanced styling and component design giving you the quality appearance and performance you have come to expect from Freighter.



Freighter's extra short goose neck optimises deck length to maximise pallet capacity.

Multi-volt LED lights are standard, together with standard and heavy duty connectors, allowing simple truck changes.

The Freighter Options to suit your needs

- Double Drop Deck Floor
- Disc Brakes
- Aluminium Floor
- Alloy Wheels
- Fork rated floor
- Lightweight alloy gates or galvanised steel
- Hub odometer
- Mezzanine floor double loader system (with optional power lift)
- Load binders and winches
- Extra toolboxes
- Water Tank(s)

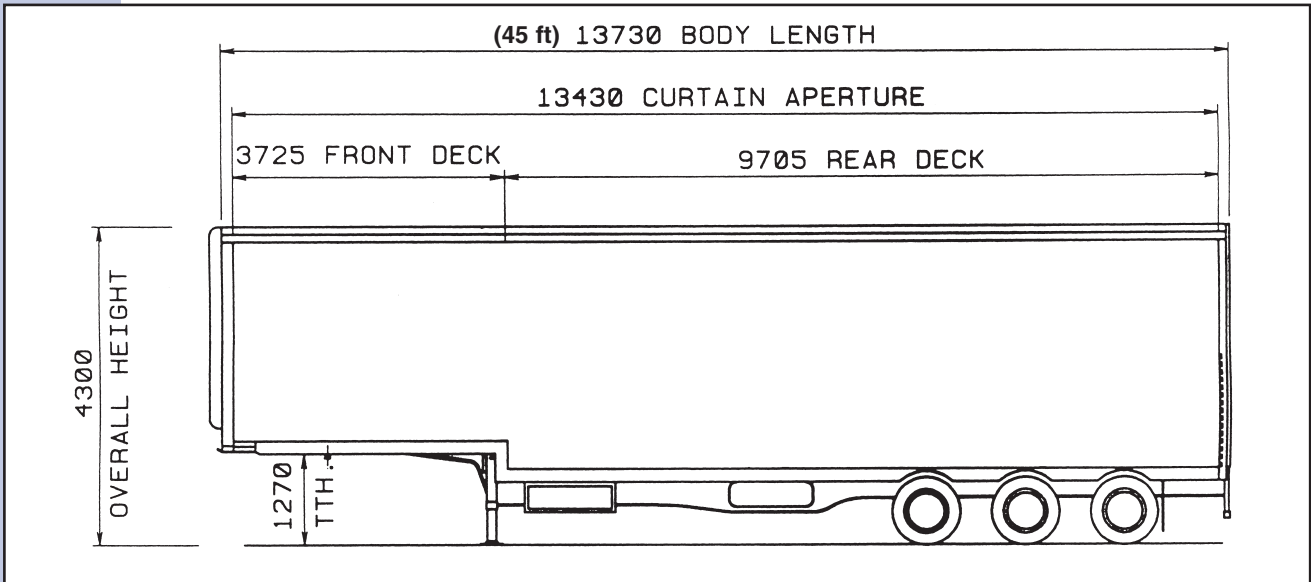

Drop Deck T-Liner Specifications (Nominal)

Dimensions

Length	13730mm (Nominal)
Aperture Height	Front - 2730mm Rear - 3105mm (45mm less under pelmet)
Aperture Length	13430mm
Rear Door Opening	H-3145mm W-2390mm
Skidplate Height	1270mm
Kingpin Location	1430mm from front
Suspension Location	9500mm (max.) from kingpin
Drop Height	375mm

Body

Sliding Posts	2 per side
Curtains	Pocketed straps with rave hook
Front Wall	Bevelled with full height white bow front.
Rear Doors	FRP panels & double lock rods. Antirack standard on inside of doors.
Roof	Aluminium
Pelmet	Black

Frame

Bumper	Square.
Skidplate	8mm with 50mm bolt-in kingpin
Base Frame	1040mm mainrail centres. 12mm top flange. 16mm bottom flange.
Floor	3mm steel checkerplate
Coaming	100 x 45 R.S.J. (Raised 23mm)

Brakes

420 x 178mm (16.5" x 7") S' Cam to A.D.R. 38.
PBR male and female couplings at front.

Underbody

Toolbox	1 standard dropframe. Kerbside.
Tyre Carrier	Integral. 2 Wheel.

Load Restraint

Tie Rails	25mm NB Pipe both sides.
Coaming Pockets	To suit 6 gates & 2 sliding posts per side.

Electrical

Voltage	Multi-volt
Lamps	LED to ADR 13
Couplings	Standard and heavy duty 7 pin.

Landing Gear

Rocker Foot	2 speed
-------------	---------

Paint

1 Colour 2K	Coamings, toolbox & hubs
Underside	Silver

Mudguards

Extruded aluminium splashguards with sprayguard flaps fitted to rear of suspension group.

Suspension

Intraax Low-Ride

Axles

Intraax integral with suspension.
5-spoke spider, dual rim, grease lubricated hubs.



Unique Pelmet Design & Facet Front

Creates greater loading clearance and reduces curtain wear. Facet front corners maximise load capacity.



Sliding Posts

Easy to use and over centre mechanism reduces driver effort.



Freighter Gooseneck

The Freightier drop deck trailer gooseneck is specially designed to maximise load length and pallet capacity.



Mezzanine loader system (option)

Removable mezzanine double loader system ideal for fragile freight and simplifies route service unloading.



Superior Chassis Design

Developed through a computer-aided design process, Freightier's chassis delivers optimum strength and durability for long life in Australian conditions with lowest possible contribution to tare weight.

Legendary Freightier finish, long-term performance & support

- Detailed, uncompromising pre-delivery inspections
- National warranty, parts and service network
- Computer designed chassis delivers optimum strength and durability
- All steel components designed and manufactured in-house
- Use of highest quality components and genuine plan of continuous improvement
- Custom manufacturing also delivers special customised configurations for individual requirements – just ask your local Freightier dealer



Check out the latest models and deals at these Freightier Dealers. www.maxitrans.com.au

MaxiTRANS Aust Pty Ltd

Victoria (03) 8368 1111

Mildura Truck Centre

Sunraysia (03) 5021 2122

SX Trailers

NSW (02) 9755 3333

CMV Trailer Sales

SA (08) 8268 4422

New Zealand

Auckland (09) 267 5714

Freightier Maxi-CUBE QLD

Qld (07) 3277 5511

Roadwest Transport

WA (08) 9272 4111